



PLX-Pure Lead High Rate

PLX12-450FT(A) (12V450W)



Specifications

Rated Voltage	12V	
Nominal Rate ($W_{15}, 1.67V/cell$)	450W	
Nominal Capacity($C_{10}, 1.80V/cell$)	110Ah	
Dimension	Length	559±2mm (22.01 inches)
	Width	125±2mm (4.92 inches)
	Container Height	227±2mm (8.94 inches)
	Total Height	227±2mm (8.94 inches)
Approx. Weight	37.7 Kg (83.7 lbs)	
Terminal	M6	
Container Material	PC-ABS flame retardant jar and cover to UL94 V-0	
Rated Capacity (25°C)	125.6 Ah	(20hr, 6.28A, 1.80V/cell)
	110.0 Ah	(10hr, 11.0A, 1.80V/cell)
	110.0 Ah	(5hr, 22.0A, 1.75V/cell)
	103.8 Ah	(3hr, 34.6A, 1.75V/cell)
	89.2 Ah	(1hr, 89.2A, 1.67V/cell)
Max. Discharge Current	1320A	
Internal Resistance (25°C)	Approx. 4.0mΩ(Fully charged)	
Operating Temp.Range	Discharge	-40 ~ 65°C (-40 ~ 149°F)
	Charge	0 ~ 40°C (32 ~ 104°F)
	Storage	-20 ~ 40°C (-4 ~ 104°F)
Nominal Operating Temp. Range	25±3°C (77±5°F)	
Max.Charging Current(25°C)	33.0A	
Charge voltage(25°C)	Float	13.62V
	Temp. Coefficient	-3mV/cell/°C
	Equalization	14.1~14.4V
Effect of temp. to Capacity	40°C (104°F)	103%
	25°C (77°F)	100%
	0°C (32°F)	86%
Self Discharge	<p>PLX series batteries can be stored up to 24 months at 25°C(77°F), For higher temperatures the time interval will be shorter.</p> <p>Battery needs to be given a freshening charge when the OCV approach 2.10V/cell or when the maximum storage time is reached, whichever occurs first.</p>	

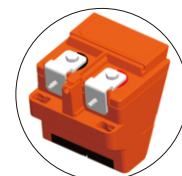

Layout

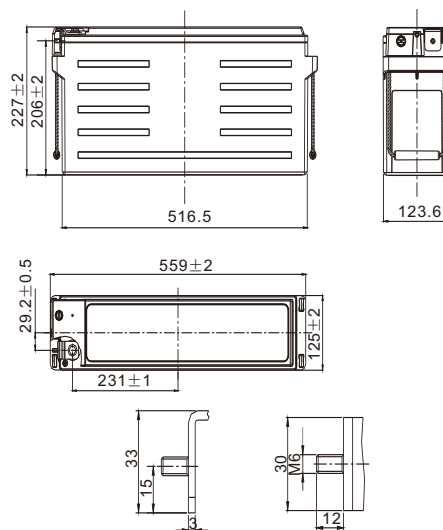

Unit: mm

Constant Current Discharge (Amperes) at 25 °C (77° F)

F.V/Time	5min	10min	15min	20min	30min	45min	1h	2h	3h	4h	5h	8h	10h	20h
1.85V/cell	309.3	238.4	186.7	160.2	123.2	95.7	78.1	45.9	33.0	25.8	21.3	14.0	10.8	6.08
1.80V/cell	348.8	263.4	203.0	172.8	132.9	101.1	81.8	47.4	33.8	26.4	21.7	14.3	11.0	6.28
1.75V/cell	388.6	287.3	218.7	184.6	140.6	105.8	85.2	48.8	34.6	26.9	22.0	14.5	11.9	6.41
1.70V/cell	425.6	297.6	232.4	194.8	146.4	109.6	87.9	49.7	35.2	27.3	22.4	14.7	12.0	6.53
1.67V/cell	483.3	310.7	245.6	200.9	148.6	111.6	89.2	50.3	35.5	27.6	22.7	14.8	12.1	6.53
1.60V/cell	532.4	331.4	261.1	209.2	151.8	114.7	91.2	51.2	36.1	28.0	22.8	15.0	12.2	6.63

Constant Power Discharge (Watts/cell) at 25 °C (77° F)

F.V/Time	5min	10min	15min	20min	30min	45min	1h	2h	3h	4h	5h	8h	10h	20h
1.85V/cell	579.8	457.7	362.3	311.7	241.4	189.2	154.9	91.7	66.0	51.8	42.9	28.4	23.3	12.4
1.80V/cell	646.6	500.5	391.5	334.1	258.8	198.6	161.4	94.2	67.4	52.7	43.4	28.8	23.6	12.8
1.75V/cell	711.4	539.7	417.5	353.7	271.6	206.3	166.8	96.3	68.6	53.5	44.0	29.1	24.0	13.0
1.70V/cell	772.0	551.9	439.3	369.7	280.3	212.3	171.0	97.9	69.5	54.1	44.6	29.5	24.2	13.2
1.67V/cell	805.6	568.6	450.0	377.3	285.7	215.1	172.7	98.6	69.9	54.5	44.9	29.6	24.3	13.2
1.60V/cell	872.8	597.8	466.9	388.7	292.2	218.7	175.1	99.6	70.6	55.0	45.2	29.8	24.5	13.3



PLX-Pure Lead High Rate PLX12-450FT(A) (12V450W)

Applications

- UPS
- Emergency lighting
- Emergency power supply
- Electrical starting
- Power tools

General Features

- 15 years design life(25°C)
- Premium ABS+PC jar & covers, Flame Retardant to UL94 V-0
- High-rate performance, high energy density
- High quality AGM separators minimize electrical resistance to allow high current discharging properties

Standards

- Compliance with IEC 60896 standard
- Classified as "Very Long Life" according to Eurobat
- CE, UL Certified
- Manufactured in Leoch®IATF 16949, OHSAS 18001, ISO 9001 and ISO 14001 certified production facilities

Discharge Characteristics

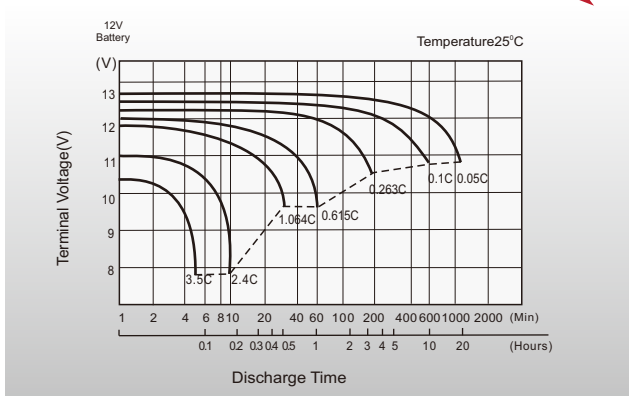

Float Charging Characteristics

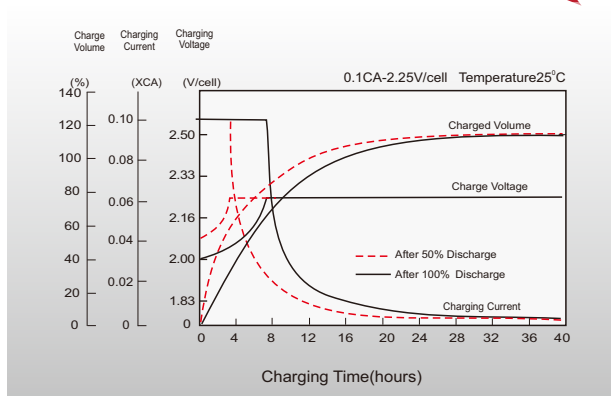

Effects of Temperature on Discharging Time

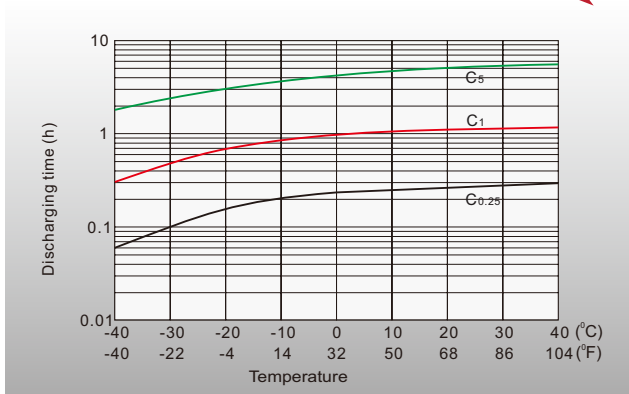

Self-discharge Characteristics

